

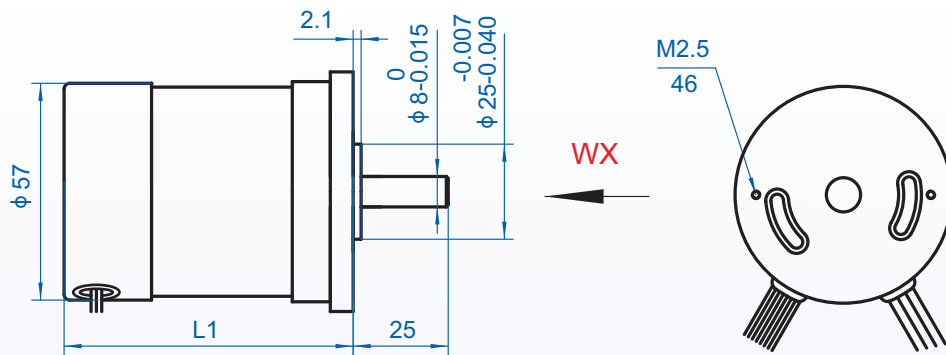

### 机座 Diameter 57 mm

- 1、使用环境: -10—40°C  
Environmental conditions: -10—40°C
- 2、极数/相数: 4/3  
Number of Poles /phase: 4/3
- 3、磁钢材料: 粘结钕铁硼  
Magnet material: Bonded NdFeB
- 4、绝缘等级: B  
Insulation Class: B
- 5、可以提供电压、转轴等专门设计  
We can design the special voltage and shaft, and so on.



型号 Model		57ZWX01	57ZWX02	57ZWX03
电压 Voltage	V	36		
空载转速 No load speed	rpm	5200	5200	5200
额定转矩 Rated torque	Nm	0.11	0.22	0.32
额定转速 Rated speed	rpm	4000	4000	4000
额定电流 Rated current	A	1.9	3.3	4.8
最大转矩 Torque ( max )	Nm	0.30	0.55	0.80
最大转矩时的电流 At Torque ( max ) Current	A	4.5	7.4	9.5
惯量 Rotor inertia	Kgmm <sup>2</sup>	7.5	11.9	17.3
反电势 Back-EMF constant	V/krpm	4.5	4.82	4.87
转矩常数 Torque Constant	Nm/A	0.0735	0.0787	0.080
电阻 Resistance(20°C)	ohm	1.65	0.70	0.48
重量 Weight	Kg	0.50	0.75	1.00
长度 L1	mm	56	76	96
铁芯长度 Rotor: La	mm	20	40	60

# 机座 Diameter 57 mm | 无刷电机 BL MOTORS

